

Case Assembly (Back View)

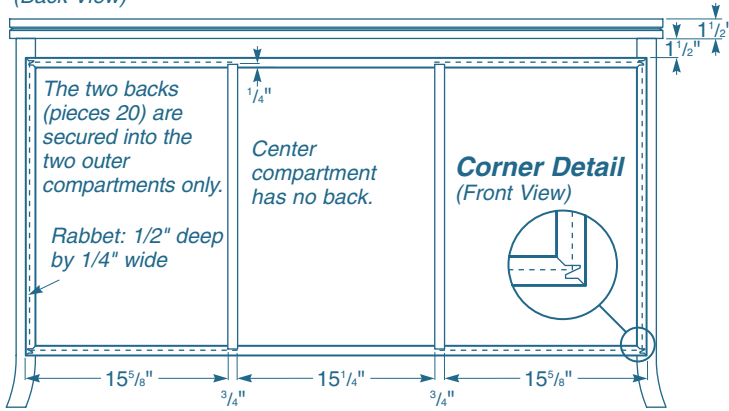

Drawer Sides (Top and Inside Views)

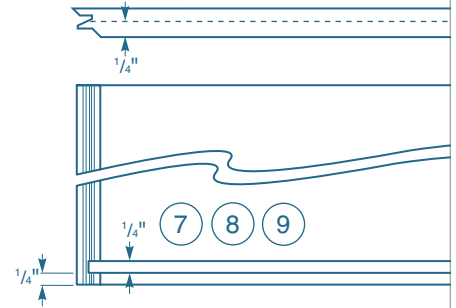

Countertop (Side and Top Views)



Case Side (Side View)

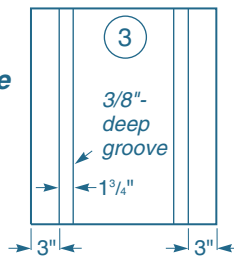

Leg (Front Views)

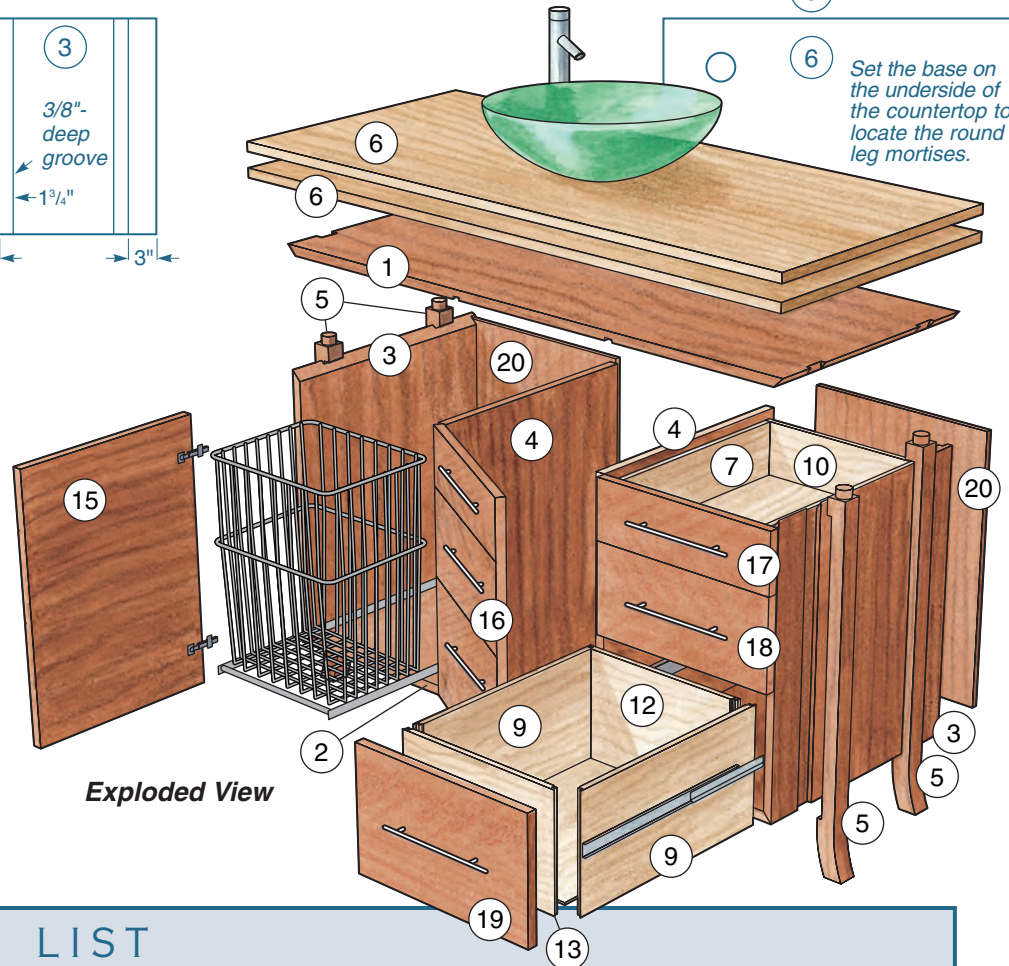
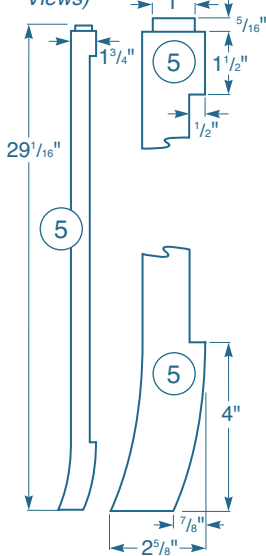

Set the base on the underside of the countertop to locate the round leg mortises.

MATERIAL LIST

	T x W x L	T x W x L	
1 Case Top (1)	3/4" x 19 3/4" x 48"	11 Middle Drawer Front/Back (2)	1/2" x 13 7/8" x 6 5/8"
2 Bottom (1)	3/4" x 19 3/4" x 48"	12 Bottom Drawer Front/Back (2)	1/2" x 13 7/8" x 9 1/4"
3 Sides (2)	3/4" x 19 3/4" x 23"	13 Drawer Bottoms (3)	1/4" x 13 3/8" x 17 1/2"
4 Dividers (2)	3/4" x 19 1/4" x 22"	14 Door/Drawer Blank (1)	3/4" x 23" x 47 7/8"
5 Legs (4)	1 3/4" x 2 5/8" x 29 1/16"	15 Left Door* (1)	3/4" x 23" x 15 7/8"
6 Countertop (2)	3/4" x 20 1/2" x 52 1/2"	16 Middle Door* (1)	3/4" x 23" x 15 7/8"
7 Top Drawer Sides (2)	1/2" x 18" x 4 1/4"	17 Top Drawer Face* (1)	3/4" x 5 3/8" x 15 7/8"
8 Middle Drawer Sides (2)	1/2" x 18" x 6 5/8"	18 Middle Drawer Face* (1)	3/4" x 7" x 15 5/8"
9 Bottom Drawer Sides (2)	1/2" x 18" x 9 1/4"	19 Bottom Drawer Face* (1)	3/4" x 10 3/8" x 15 5/8"
10 Top Drawer Front/Back (2)	1/2" x 13 7/8" x 4 1/4"	20 Cabinet Backs (2)	1/2" x 16" x 22"

* Pieces 15 - 19 are cut from the drawer/door blank, piece 14.